



VL Heavy Duty Series

CNC VERTICAL LATHES **(HEAVY DUTY Series)**

TKV - 760 / TKV - 900 / TKV - 1100 / TKV - 1600

TKV - 2000 / TKV - 2500 / TKV - 3000 / TKV - 3500

TKV - 4500 / TKV - 6000 / TKV - 7000

CNC-TAKANG

CNC-TAKANG CO., LTD.
MANUFACTURER & EXPORTER

TKV HEAVY DUTY SERIES



TKV-1100



Crossed roller bearing



Gear box



TKV-2000M

TKV HEAVY DUTY SERIES



One-piece column with wide span
Box structure casting for better rigidity



One-piece machine base with built-in gearbox and spindle



Roller gear driver



Cross-rail ensures parallelism and stability by positioning lock with hydraulic clamping

TKV HEAVY DUTY SERIES

▼Heavy duty tool assembly for turning



Standard Type ATC

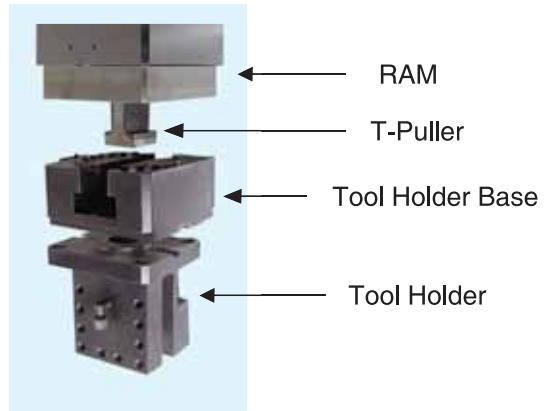

Rigid tool system with T-puller and hydraulic clamping



M-Type ATC

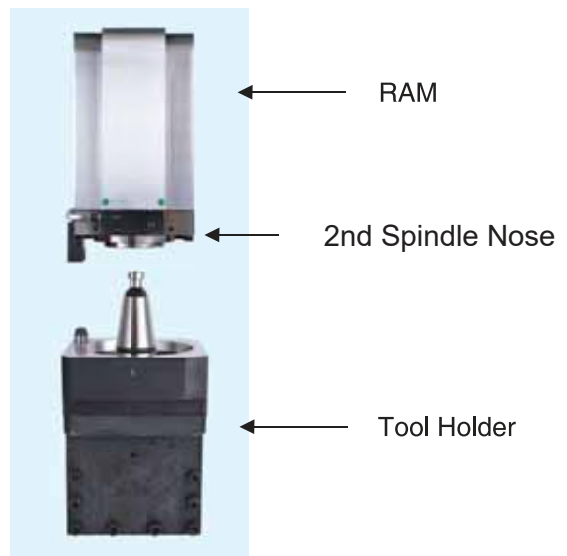

BT50-200

(Two face contact tooling) (Option)



M-Type ATC (Solid Lock)

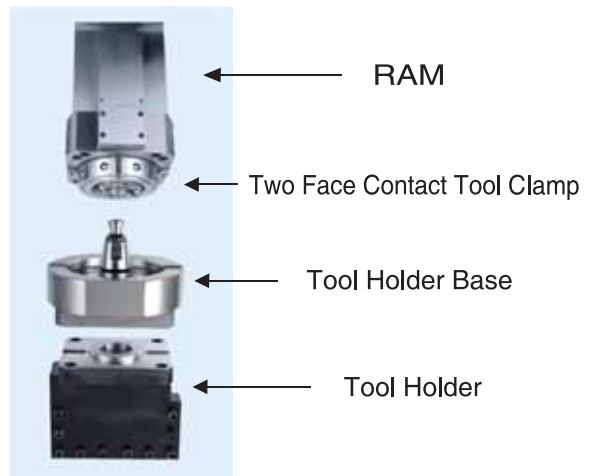

▼ Standard ATC tooling system

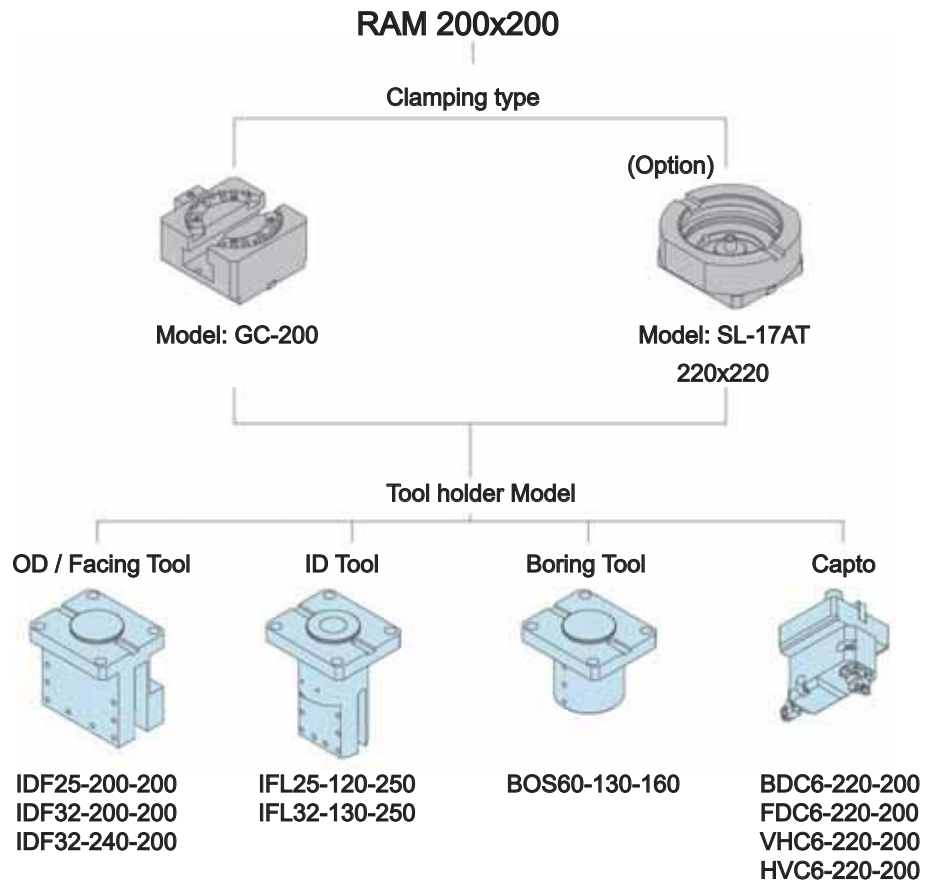

▼ M-type ATC tooling system

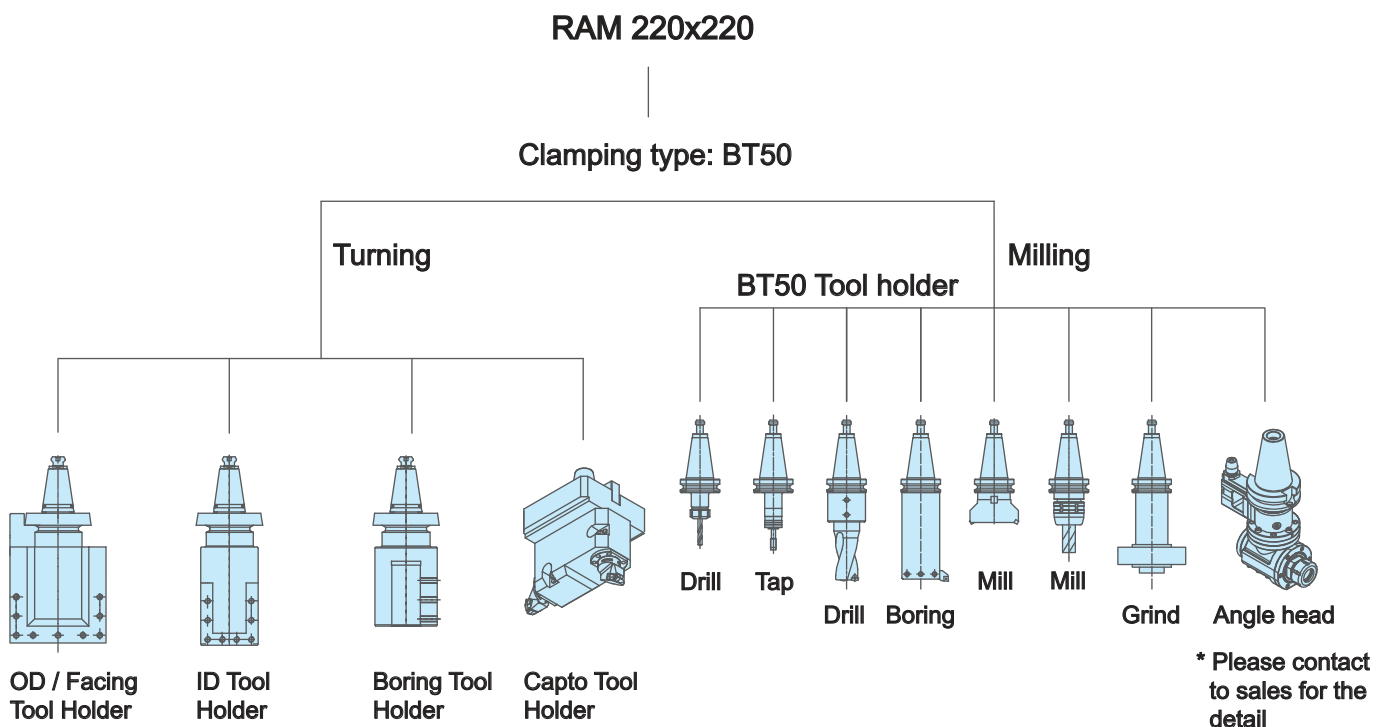

TKV-1600 / 2000 / 2500 / 3000

▼Standard ATC tooling system

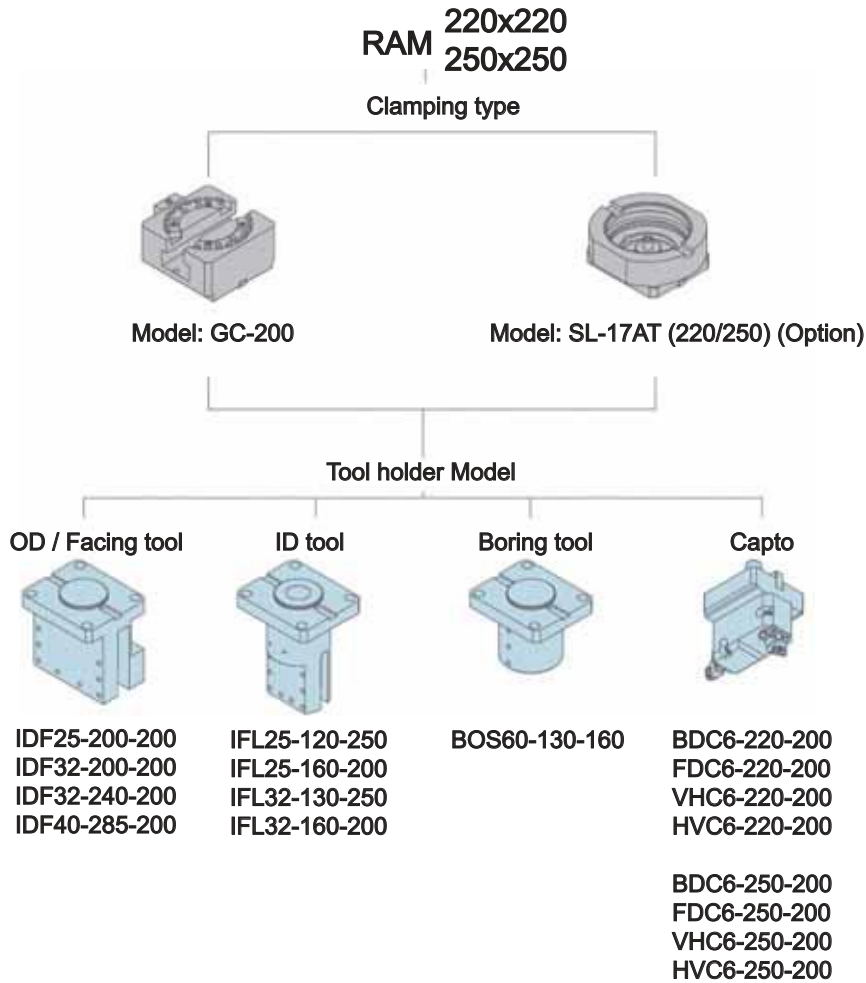

▼M-type ATC tooling system

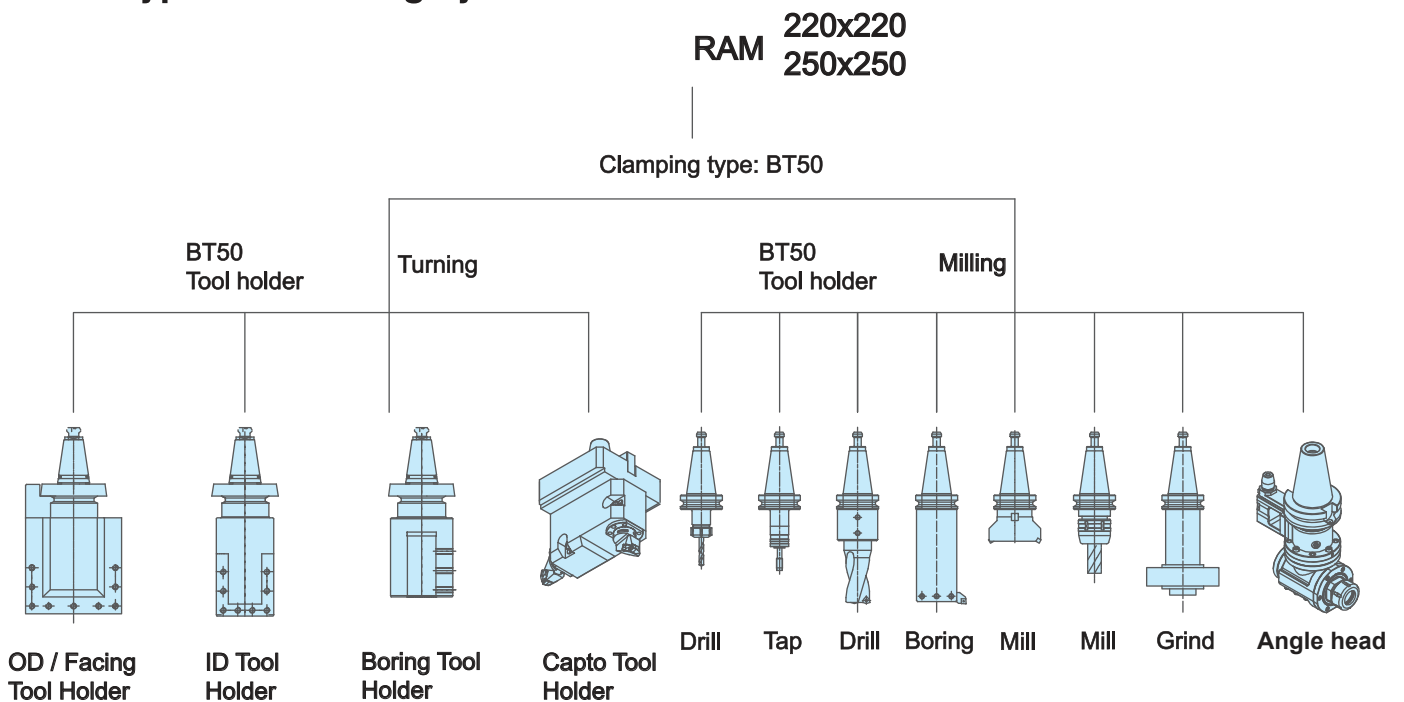

TKV HEAVY DUTY SERIES

▼ Solid-Lock ATC tool system (Option)

RAM

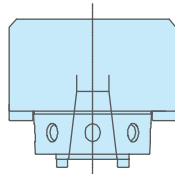

220x220
250x250
300x300

Turning

Milling

Tool holder base

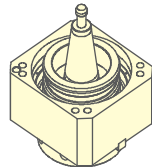
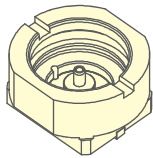

SL-17AT / SL-22AT SL-17AM / SL-22AM

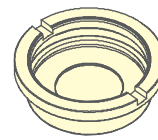

Cover

BT50 Tool holder

Angle head
ATCM90 / ATCM90-2

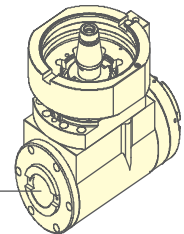

Tool holder

OD / Facing tool

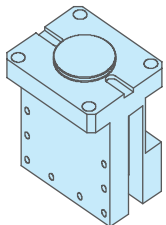

IDF25-200-200
IDF32-200-200
IDF32-240-200
IDF32-285-200
IDF40-285-200

Capto

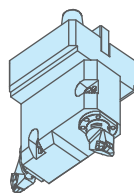

BDC6-220-200
FDC6-220-200
VHC6-220-200
HVC6-220-200
BDC6-250-200
FDC6-250-200
VHC6-250-200
HVC6-250-200
BDC6-300-250
FDC6-300-250
VHC6-300-250
HVC6-300-250

ID tool

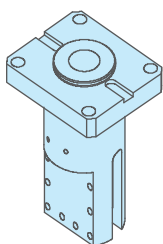

Boring tool

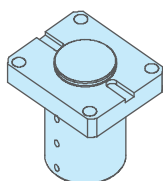

IFL25-120-250
IFL25-160-200
IFL32-130-250
IFL32-160-200

BOS60-130-160

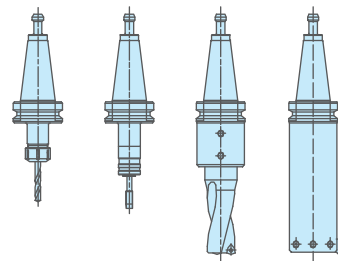

Drill Tap Drill Boring

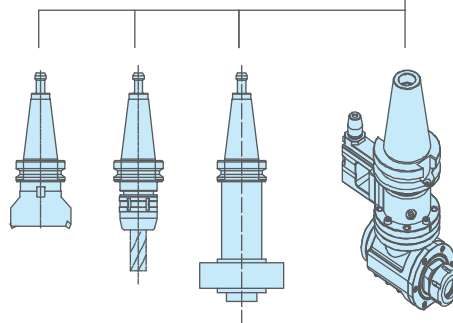

Mill Mill Grind Angle head

Tool holder BT40 /
Tool holder BT50

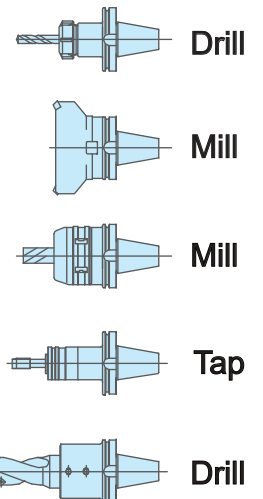

TKV HEAVY DUTY SERIES

▼ Tool holder and dimension (Unit: mm)

Tool holder base

GC-200
(Gear Coupling)

SL-17AT (220 / 250)
(Two face contact tooling)

SL-17AM (220)
(Two face contact tooling)

SL-22AT (300)
(Two face contact tooling)

SL-22AM (250 / 300)
(Two face contact tooling)

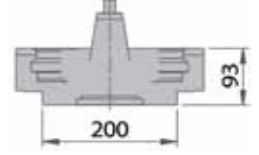
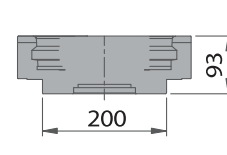
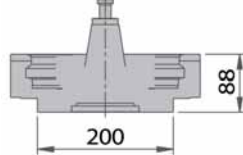
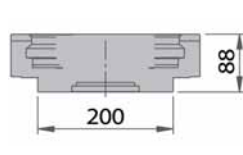
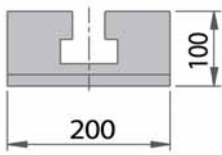

GC-200 / RG250 / SL-17AT / SL-17AM / SL-22AT / SL-22AM

OD / Facing tool holder

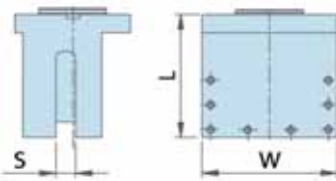

ID / Facing tool holder

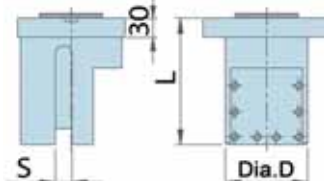

Boring tool holder

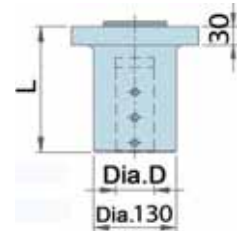

Model	L	S	W
IDF25-200-200	200	25	200
IDF32-200-200	200	32	200
IDF32-240-200	200	32	240
IDF32-285-200	200	32	285
IDF40-285-200	200	40	285

Model	L	D	S
IFL25-120-250	250	120	25
IFL25-160-200	200	160	25
IFL32-130-250	250	130	32
IFL32-160-200	200	160	32

Model	L	D	W
BOS40-120-200	200	40	120
BOS50-120-200	200	50	120
BOS60-120-200	200	60	120
BOS60-130-160	160	60	130

Capto Tool holder

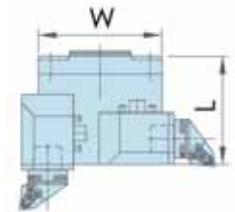
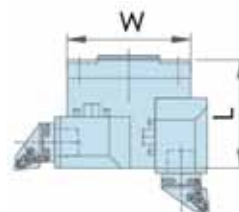
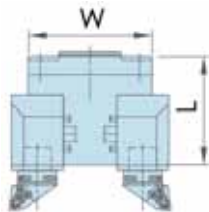
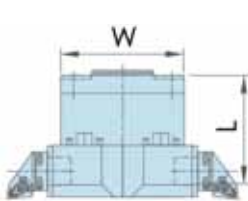

Model	L	W
BDC6-220-200	200	220
BDC6-250-200	200	250
BDC6-300-250	250	300

Model	L	W
FDC6-220-200	200	220
FDC6-250-200	200	250
FDC6-300-250	250	300

Model	L	W
VHC6-220-200	200	220
VHC6-250-200	200	250
VHC6-300-250	250	300

Model	L	W
HVC6-220-200	200	220
HVC6-250-200	200	250
HVC6-300-250	250	300

BT50 Tool holder

OD / Facing tool holder

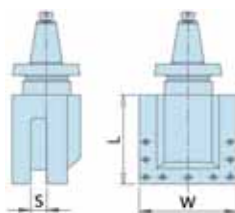

ID / Facing tool holder

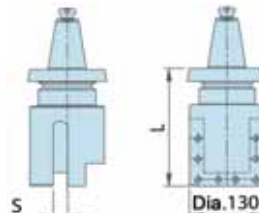

Boring tool holder

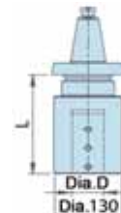

Model	L	S	W
BT50-IDF25-200-200	200	25	200
BT50-IDF32-200-200	200	32	200
BT50-IDF32-240-200	200	32	240

Model	L	S
BT50-IFL25-130-200	200	25
BT50-IFL32-130-200	200	32

Model	L	D
BT50-BOS40-130-200	200	40
BT50-BOS50-130-200	200	50
BT50-BOS60-130-200	200	60

Note: W200 is only for □220 / W240 is only for □250

TKV HEAVY DUTY SERIES

▼ Jaw Dimension (Unit: mm)

TKV-900, TKV-1100 Series (Manual)

C Type (Standard)

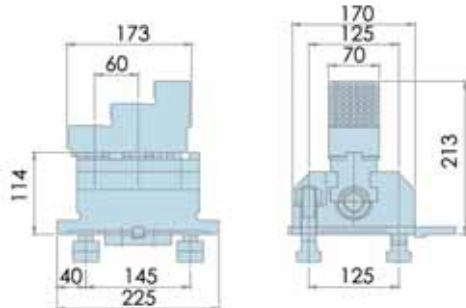

F Type

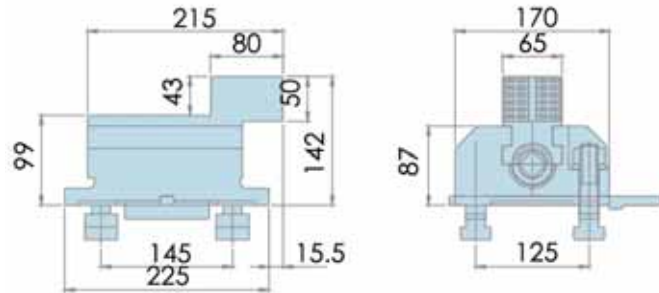

TKV-1600, TKV-2000 Series (Manual)

C Type (Standard)

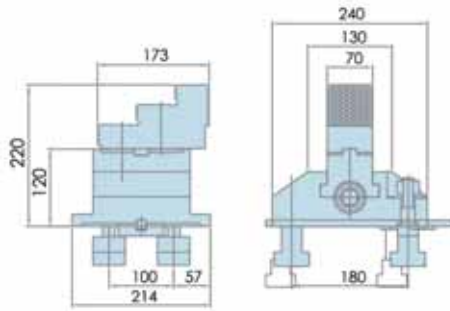

F Type

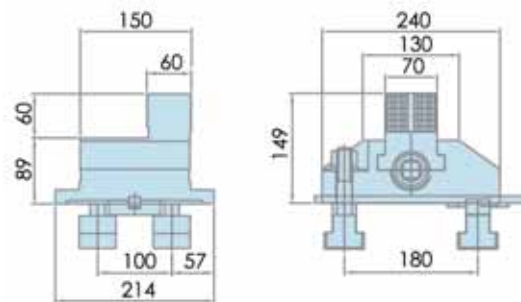

TKV-2500, TKV-3000, TKV-3500, TKV-4500, TKV-6000, TKV-7000 Series (Manual)

C Type (Standard)

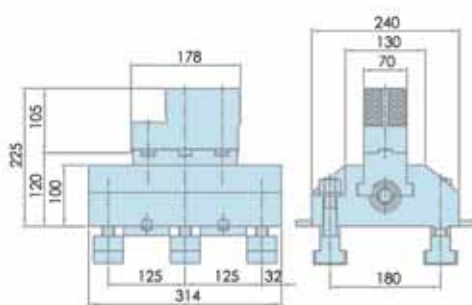

F Type

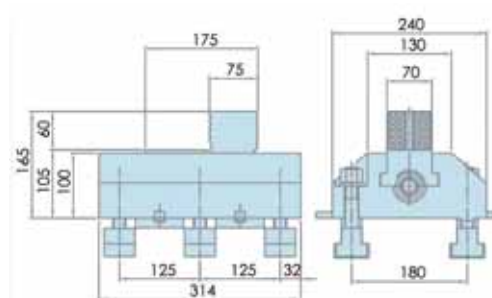

▼Clamping Capacity with jaws

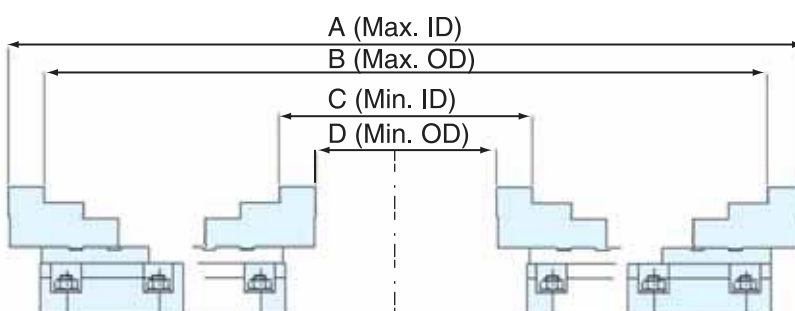

MODEL	A	B	C	D
TKV-900	1050	900	160	50
TKV-1100	1150	1040	300	190
TKV-1600	1340	1230	370	250
TKV-2000	1720	1600	420	300
TKV-2500	2120	2000	750	530
TKV-3000	2500	2220	750	530
TKV-3500	2980	2770	980	700
TKV-4500	4020	3740	980	700
TKV-6000	5000	4750	1350	1100
TKV-7000	6000	5750	1350	1100

TKV HEAVY DUTY SERIES

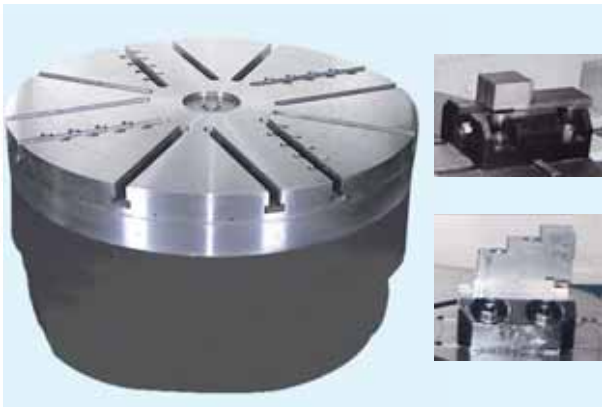

Manual 4-jaw table

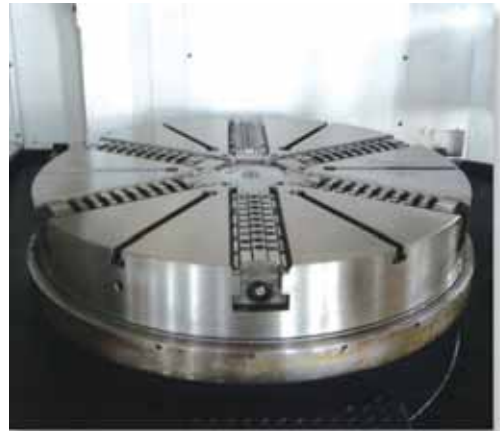

Hydraulic chuck (Option)



Milling attachment
(Option)



Tool presetter
(Option)

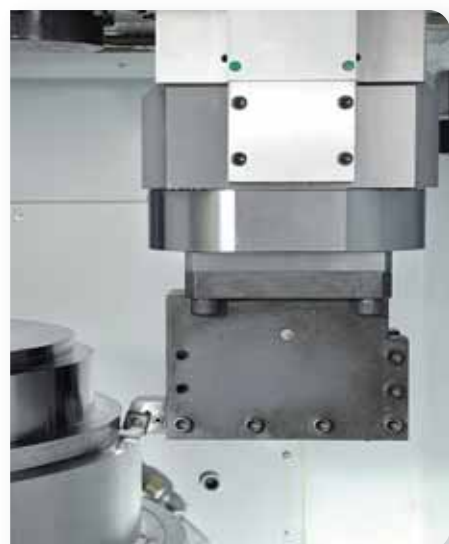

Solid Lock System (Option)

TKV HEAVY DUTY SERIES

▼ Machine dimension (Unit: mm)

TKV-760 / TKV-900 / TKV-1100 series

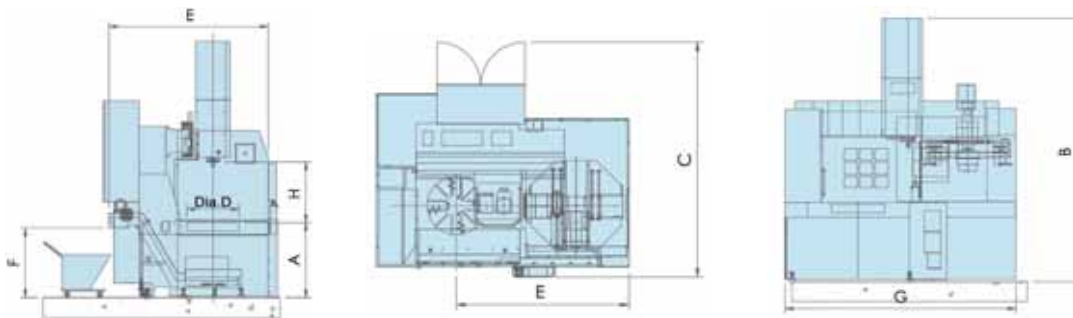

	A	B	C	D	E	F	G	H
TKV-760	1150	4700	3600	610	2450	1065	3450	920
TKV-760M	1150	4800	3600	610	2450	1065	3450	920
TKV-900	1150	4700	3600	800	2450	1065	3450	920
TKV-900M	1150	4800	3600	800	2450	1065	3450	920
TKV-1100	990	4200	4020	1000	2735	1000	4060	925
TKV-1100M	1025	4850	4020	1000	2735	1000	4060	925

Movable cross-rail (Option)

	A	B	C	D	E	F	G	H
TKV-1100	990	4300	4020	1000	2735	1000	4060	500-1100
TKV-1100M	1025	5000	4020	1000	2735	1000	4060	500-1100

TKV-1600 / TKV-2000 series

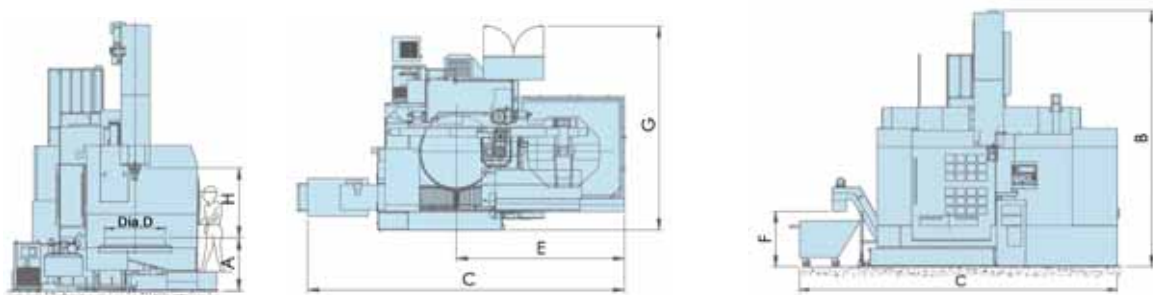

	A	B	C	D	E	F	G	H
TKV-1600	1100	5250	6480	1250	3277	1200	4875	650-1450
TKV-1600M	1100	5650	6850	1250	3625	1200	4875	635-1435
TKV-2000	1100	5250	7035	1600	3500	1200	5175	650-1450
TKV-2000M	1100	5650	7380	1600	3825	1200	5175	635-1435

TKV-2500 / TKV-3000 series

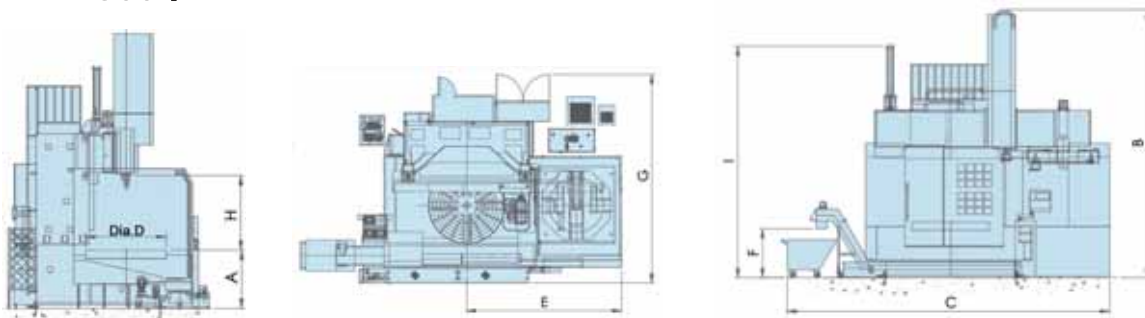

	A	B	C	D	E	F	G	H	I
TKV-2500	1455	6635	7970	2000	3960	1280	5532	785-1785	6030
TKV-2500M	1455	6970	8400	2000	4120	1280	5532	785-1785	6030
TKV-3000	1455	6635	8295	2500	3915	1280	5564	785-1785	6030
TKV-3000M	1455	6970	8580	2500	4200	1280	5564	785-1785	6030

TKV HEAVY DUTY SERIES

▼ Machine dimension (Unit: mm)

TKV-3500 / TKV-4500 / TKV-6000 / TKV-7000

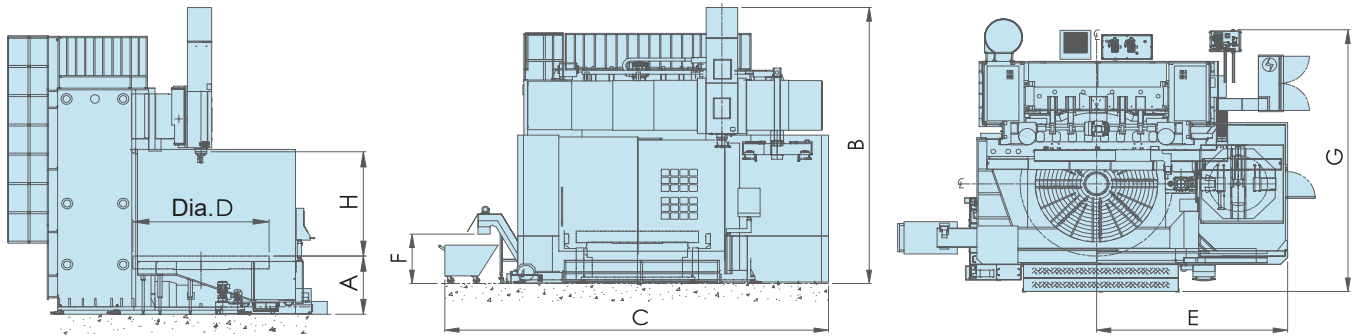

	A	B	C	D	E	F	G	H
TKV-3500	1365	7150	9400	3000	4680	1280	6750	2380
TKV-3500M	1365	7150	9400	3000	4680	1280	6750	2380
TKV-4500	1365	7150	10200	4000	5130	1280	7200	2380
TKV-4500M	1365	7150	10200	4000	5130	1280	7200	2380
TKV-6000	1560	10000	11500	5000	6400	N/A	10200	3000
TKV-6000M	1560	10600	11500	5000	6400	N/A	10200	3000
TKV-7000	1560	10000	12500	6000	6900	N/A	11000	3000
TKV-7000M	1560	10600	12500	6000	6900	N/A	11000	3000

▼ Work range and interference (Unit: mm)

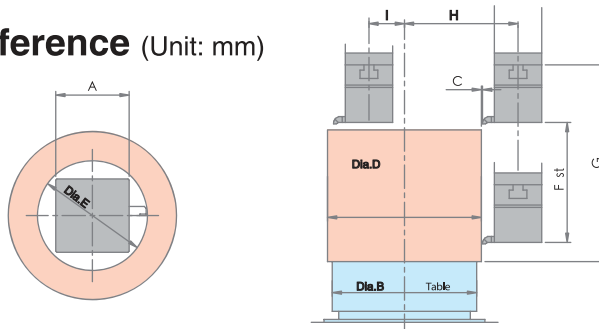

MODEL	A	B	C	D	E	F	G	H	I
TK-760	200	610	10	800	300	600	925	650	100
TK-900	200	800	15	900	300	600	925	750	100
TK-1100	200	1000	20	1200	300	700	925	750	100
TKV-1600	220	1250	20	1600	330	900	650-1450	950	200
TKV-2000	220	1600	20	2000	330	900	650-1450	1150	200
TKV-2500	250	2000	40	2500	360	1200	785-1785	1450	300
TKV-3000	250	2500	5	2970	360	1200	785-1785	1650	300
TKV-3500	300	3000	37	3600	450	1500	880-2380	2000	300
TKV-4500	300	4000	37	4500	450	1500	880-2380	2450	300
TKV-6000	400	5000	50	6000	580	2200	1200-3000	3500	100
TKV-7000	400	6000	50	7000	580	2200	1200-3000	4000	100

▼ Work table and T-Slot dimension (Unit: mm)

TKV-900 series

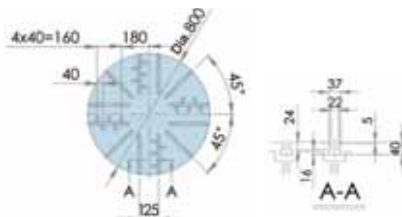

TKV-1100 series

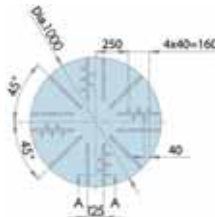

TKV-2500 series

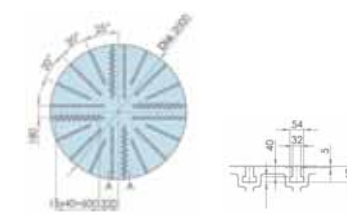

TKV-3000 series



TKV-1600 series

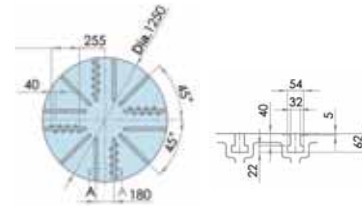

TKV-2000 series

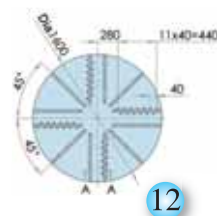

TKV-3500 series

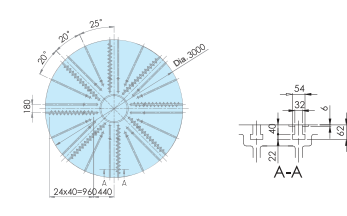

TKV-4500 series

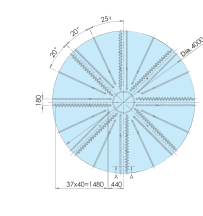

TKV HEAVY DUTY SERIES

▼ Table-speed and torque

TKV-760 18.5/22kw, 2steps

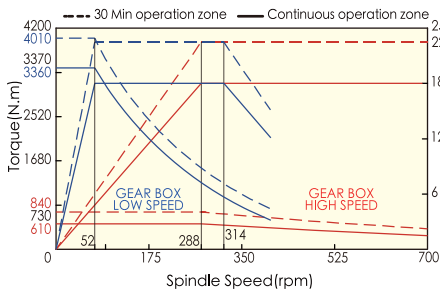

TKV-760M 30/37kw, 2steps

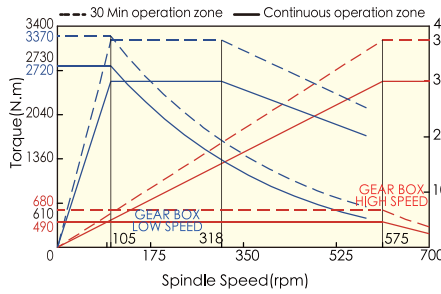

Live tool spindle 11/15kw, 2steps

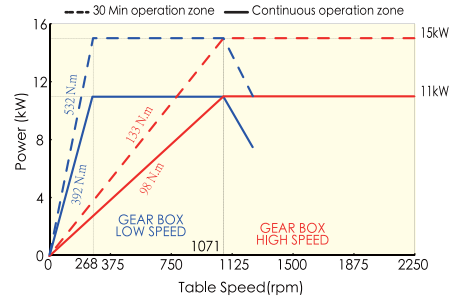

TKV-900 18.5/22kw, 2steps

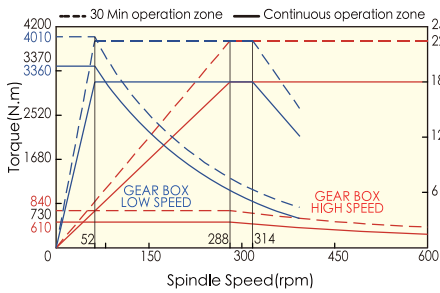

TKV-900M 30/37kw, 2steps

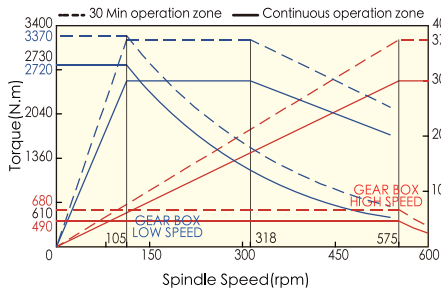

Live tool spindle 15/18.5kw, 2steps

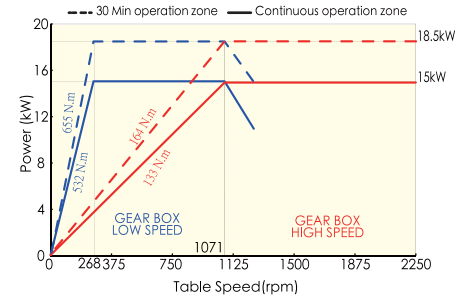

TKV-1100 series 30/37kw, 2steps

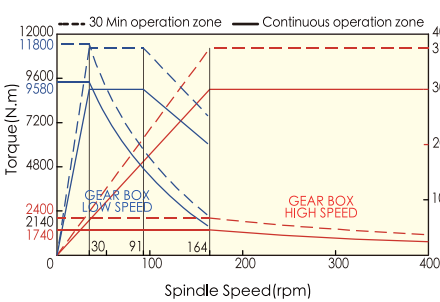

TKV-1600 series 37/45kw, 2steps

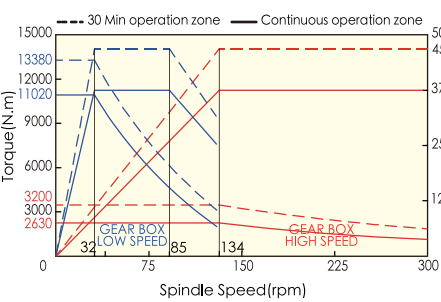

TKV-2000 series 37/45kw, 2steps

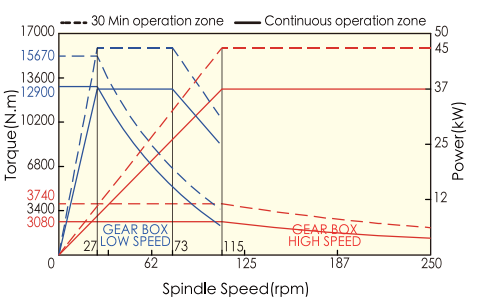

TKV-2500 series 60/75kw, 2steps

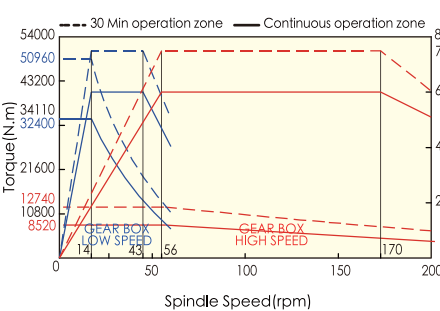

TKV-3000 series 60/75kw, 2steps

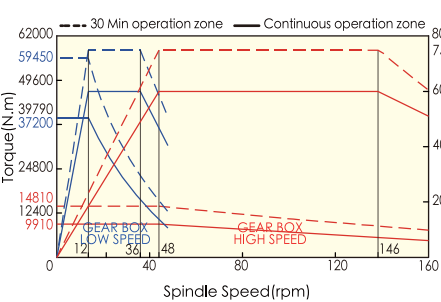

TKV-3500 60/75kw

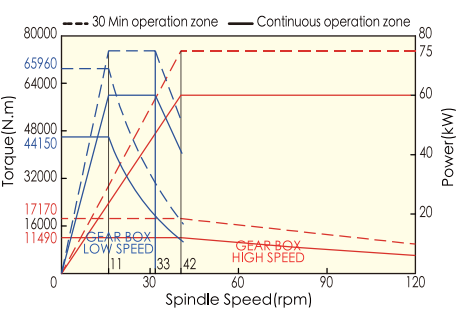

TKV-3500M 60/75kw x 2 motors

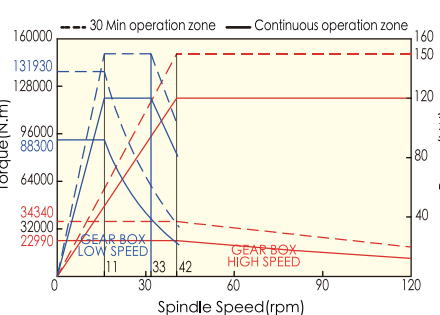

TKV-4500 60/75kw

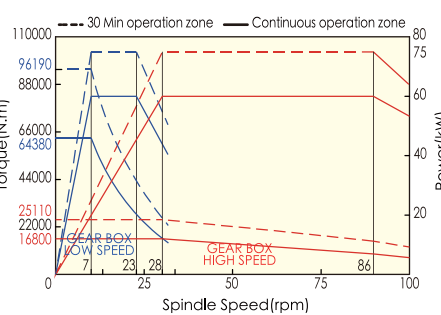

TKV-4500M 60/75kw x 2 motors

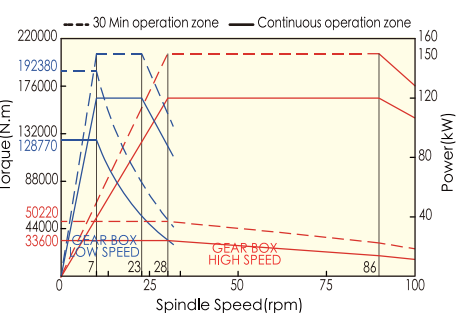

TKV-760 / 900 / 1100 / 1600

SPECIFICATIONS

MODEL	DESCRIPTION	TKV-760	TKV-760M	TKV-900	TKV-900M	TKV-1100	TKV-1100M	TKV-1600	TKV-1600M	
Capacity	Max. swing diameter	850 mm (33.4")		950 mm (37.4")		1200 mm (47.2")		1600 mm (62.9")		
	Max. turning diameter	850 mm (33.4")		950 mm (37.4")		1200 mm (47.2")		1600 mm (62.9")		
	Distance from ram to table	925 mm (36.4")				925 mm (36.4") / OPT. 500-1100 mm (19.6"-43.3")		650-1450 mm (25.5"-57")	635-1435 mm (25"-56")	
	Max. turning height	650 mm (25.5")				650 mm (25.5") / OPT. 800mm (31.4")		1200 mm (47")	1170 mm (46")	
	Max. workpiece weight	1500 kgs		2000 kgs		3500 kgs		5000 kgs		
Spindle	Table diameter	610 mm (24")		610 mm (24")		1000 mm (39.3")		1250 mm (49.2")		
	Range of table speed	5-700 rpm		5-600 rpm		3-400 rpm		3-300 rpm		
	Change gear speed	2 Steps				2 Steps				
	Spindle nose	A2-11				-				
	Driving tool spindle speed	-	50-2250 rpm	-	50-2250 rpm	-	50-2250 rpm	-	50-2250 rpm	
ATC	Number of tool station	12						12	16	
	Tool size	□ 25 mm, □ 32 mm								
	Cross-section of ram	200 x 200 mm	220 x 220 mm	200 x 200 mm	220 x 220 mm	200 x 200 mm	220 x 220 mm	220 x 220 mm	220 x 220 mm 250 x 250 mm	
Feed	Rapid rate (X-axis)	10 M / min								
	Rapid rate (Z-axis)	10 M / min								
	Horizontal travel (X-axis)	-100 + 650 mm		-100 + 750 mm		-100 + 750 mm		-200 + 950 mm		
	Vertical travel (Z-axis)	600 mm (23.6")				700 mm (27.6")		900 mm (35.4")		
	Cutting federate	5000 mm / min								
	Feed override	0-150 %								
	Cross-rail travel	Fixed				Fixed / OPT. 200 x 3 steps		800 (200 x 4 steps)		
	CNC controller system	Fanuc 0iTF		Fanuc 0iTF		Fanuc 0iTF		Fanuc 0iTF		
Motor	Spindle motor (Cont. / 30 min)	18.5 / 22 kw	30 / 37 kw	18.5 / 22 kw	30 / 37 kw	30 / 37 kw		37 / 45 kw		
	Feed motor (X / Z axis)	4 / 4 kw		4 / 4 kw		4 / 4 kw		7 / 7 kw		
	Driving tool motor	-	11 / 15 kw	-	11 / 15 kw	-	11 / 15 kw	-	11 / 15 kw	
	Power requirement	40 KVA	55 KVA	40 KVA	55 KVA	75 KVA	90 KVA	75 KVA	90 KVA	
Dimension & Weight	Floor space (L x W)	3450 x 3600 mm		3450 x 3600 mm		4060 x 4020 mm		6500 x 4900 mm	6900 x 4900 mm	
	Max. height	4500 mm	4500 mm	4500 mm	4500 mm	4000 mm	4550 mm	5200 mm	5650 mm	
	Net weight	12500 kgs	12500 kgs	13500 kgs	13500 kgs	17800 kgs	18600 kgs	24500 kgs	25300 kgs	

※THE SPECIFICATIONS ARE SUBJECT TO CHANGE WITHOUT PRIOR NOTICE.

STANDARD ACCESSORIES:

- Spindle orientation
- Hydraulic 3-jaw solid chuck, cylinder and soft jaw x 1 set
(For TKV-760~TKV-900 series)
- Table with manual 4-jaw chuck (For TKV-1100~TKV-3000)
- Table with manual 8-jaw chuck (For TKV-3500~TKV-7000)
- Hydraulic power unit
- Foot switch for hydraulic chuck
- Automatic lubrication system
- Coolant system through tool holder to inserts (3 bar)
- Coolant system with tank
- Protection door
- Hinge type chip conveyor and chip trolley
- Heat exchanger for electrical cabinet
- Splash guard
- Work light
- Warning light (R/Y/G)
- Workpiece counter
- Manual for operation and maintenance
- Manual for electrical and hydraulic circuit diagram
- Electronic manual for controller
- Tool box with tools
- Leveling bolts and pads

TKV-2000 / 2500 / 3000 / 3500

SPECIFICATIONS

MODEL	DESCRIPTION	TKV-2000	TKV-2000M	TKV-2500	TKV-2500M	TKV-3000	TKV-3000M	TKV-3500	TKV-3500M
Capacity	Max. swing diameter	2000 mm (78.7")		2500 mm (98.4")		3000 mm (118.1")		3600 mm (141.7")	
	Max. turning diameter	2000 mm (78.7")		2500 mm (98.4")		2970 mm (116.9")		3600 mm (141.7")	
	Distance from ram to table	650-1450 mm (25.5"-57")	635-1435mm (25"-56")	805-1805 mm (31.6"-71")	785-1785 mm (30.9"-70")	805-1805 mm (31.6"-71")	785-1785 mm (30.9"-70")	880-2380 mm (34.6"-93.7")	
	Max. turning height	1200 mm (47.2")	1170 mm (46.1")	1600 mm (62.9")		1600 mm (62.9")		2000 mm (78.7")	
	Max. workpiece weight	8000 kgs		12000 kgs		15000 kgs		30000 kgs	
Spindle	Table diameter (Manual chuck)	1600 mm (62.9")		2000 mm (78.7")		2500 mm (98.4")		3000 mm (118.1")	
	Range of table speed	3-250 rpm		5-200 rpm		5-160 rpm		3-120 rpm	
	Change gear speed	2 Steps							
	Spindle nose	-							
	Driving tool spindle speed	-	50-2250 rpm	-	50-2250 rpm	-	50-2250 rpm	-	50-2250 rpm
ATC	Number of tool station	12	16	12	16	12	16	12	16
	Tool size	□25 mm, □32 mm, □40 mm						□32 mm, □40 mm	
	Cross-section of ram	220 x 220 mm	220 x 220 mm 250 x 250 mm	250 x 250 mm		250 x 250 mm		300 x 300 mm	
Feed	Rapid rate (X-axis)	10 M / min							
	Rapid rate (Z-axis)	10 M / min							
	Horizontal travel (X-axis)	-200 + 1150 mm		-300 + 1450 mm		-300 + 1650 mm		-300 + 2000 mm	
	Vertical travel (Z-axis)	900 mm (35.4")		1200 mm (47.2")		1200 mm (47.2")		1500 mm (59.1")	
	Cutting federate	5000 mm / min						2000 mm / min	
	Feed override	0-150 %							
	Cross-rail travel	800 (200 x 4 steps)		1000 (250 x 4 steps)		1000 (250 x 4 steps)		1500 (250 x 6 steps)	
	CNC controller system	Fanuc 0iTF		Fanuc 0iTF		Fanuc 0iTF		Fanuc 0iTF	
Motor	Spindle motor (Cont. / 30 min)	37 / 45 kw		60 / 75 kw		60 / 75 kw		60 / 75 kw	60 / 75 kw x 2
	Feed motor (X / Z axis)	7 / 7 kw		5.5 / 5.5 kw		5.5 / 5.5 kw		5.5 / 5.5 kw	
	Driving tool motor	-	11 / 15 kw	-	11 / 15 kw	-	11 / 15 kw	-	15 / 18.5 kw
	Power requirement	75 KVA	90 KVA	90 KVA	105 KVA	90 KVA	105 KVA	120 KVA	210 KVA
Dimension & Weight	Floor space (L x W)	7100 x 5200 mm	7400 x 5200 mm	7600 x 5500 mm		7800 x 6100 mm		8500 x 6500 mm	
	Max. height	5250 mm	5650 mm	6650 mm	7000 mm	6650 mm	7000 mm	7400 mm	8000 mm
	Net weight	27500 kgs	28300 kgs	47000 kgs	49000 kgs	51000 kgs	53000 kgs	99000 kgs	100000 kgs

※THE SPECIFICATIONS ARE SUBJECT TO CHANGE WITHOUT PRIOR NOTICE.

OPTIONS:

- Higher power motor
- Extra hydraulic chuck and cylinder
- Dual speed gear box for driving tool spindle
- High and low pressure chucking
- Table with manual 4-jaw chuck (For TKV-760, TKV-900 series)
- Hard jaws of hydraulic chuck
- Manual guide i
- Linear scale on X / Z axis
- Lubricant chiller for spindle bearing and gear
- Special tool holder
- Tool presetter
- Higher pressure coolant through tool holder
- Tool holder base
- Extend vertical travel (Z axis)
- Air condition for electrical cabinet (STD for M series)
- Oil skimmer (Disk type)
- Scrap type chip conveyor with chip trolley
- Jig and fixture
- Turnkey project
- External power transformer
- CE mark

SPECIFICATIONS

MODEL	DESCRIPTION	TKV-4500	TKV-4500M	TKV-6000	TKV-6000M	TKV-7000	TKV-7000M
Capacity	Max. swing diameter	4500 mm (177.2")		6000 mm (236.2")		7000 mm (275.6")	
	Max. turning diameter	4500 mm (177.2")		6000 mm (236.2")		7000 mm (275.6")	
	Distance from ram to table	880-2380 mm (34.6"-93.7")		1200-3000 mm (47.2"-118")		1200-3000 mm (47.2"-118")	
	Max. turning height	2000 mm (78.7")		2600 mm (102.3")		2600 mm (102.3")	
	Max. workpiece weight	40000 kgs		80000 kgs		100000 kgs	
Spindle	Table diameter (Manual chuck)	4000 mm (157.5")		5000 mm (196.8")		6000 mm (236.2")	
	Range of table speed	1-85 rpm		1-50 rpm		1-20 rpm	
	Change gear speed	2 Steps					
	Spindle nose	-					
	Driving tool spindle speed	-	50-2250 rpm	-	50-2250 rpm	-	50-2250 rpm
ATC	Number of tool station	16	20	16	24	16	24
	Tool size	□32 mm, □40 mm					
	Cross-section of ram	300 x 300 mm		400 x 400 mm		400 x 400 mm	
Feed	Rapid rate (X-axis)	10 M / min					
	Rapid rate (Z-axis)	10 M / min					
	Horizontal travel (X-axis)	-300 + 2450 mm		-100 + 3000 mm		-100 + 4000 mm	
	Vertical travel (Z- axis)	1500 mm (59.1")		2200 mm (86.6")		2200 mm (86.6")	
	Cutting federate	2000 mm / min					
	Feed override	0-150 %					
	Cross-rail travel	1500 (250 x 6 steps)		1800 (300 x 6 steps)		1800 (300 x 6 steps)	
	CNC controller system	Fanuc 0iTF		Fanuc 0iTF		Fanuc 0iTF	
Motor	Spindle motor (Cont. / 30 min)	60 / 75 kw	60 / 75 kw x 2	60 / 75 kw	60 / 75 kw x 2	60 / 75 kw	60 / 75 kw x 2
	Feed motor (X / Z axis)	5.5 / 5.5 kw		5.5 / 5.5 kw		5.5 / 5.5 kw	
	Driving tool motor		15 / 18.5 kw	-	15 / 18.5 kw	-	15 / 18.5 kw
	Power requirement	130 KVA	230 KVA	140 KVA	250 KVA	150 KVA	270 KVA
Dimension & Weight	Floor space (L x W)	10200 x 7000 mm		12500 x 9000 mm		13000 x 11000 mm	
	Max. height	7400 mm	8000 mm	9000 mm	10000 mm	9000 mm	10000 mm
	Net weight	114000 kgs	115000 kgs	139000 kgs	140000 kgs	169000 kgs	170000 kgs

※THE SPECIFICATIONS ARE SUBJECT TO CHANGE WITHOUT PRIOR NOTICE.

CNC-TAKANG CO., LTD.

No. 72, Alley 7, Lane 98, 1st Road, Taichung Industry Park,
Taichung 40767. TAIWAN

REDMOND GARY AUST. PTY. LTD.
23 PRODUCTION AVENUE,
MOLENDINAR Q. 4214
PHONE: (07) 5594 9844 FAX: (07) 5594 9079